

FRONT VIEW

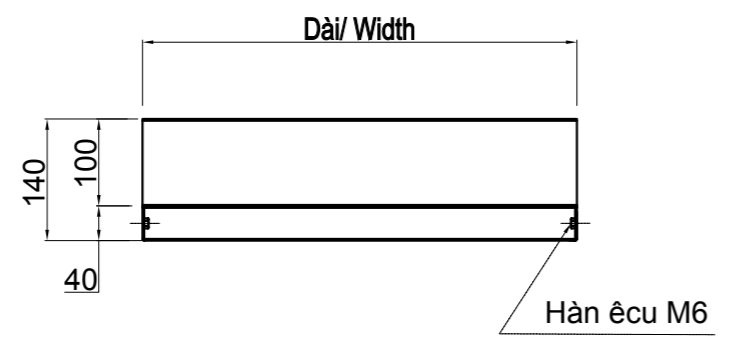

CROSS SECTION

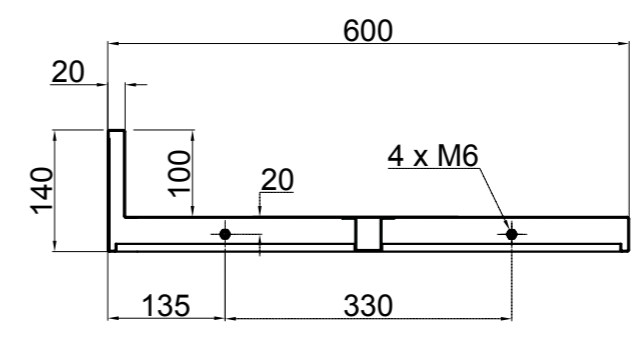

TOP VIEW

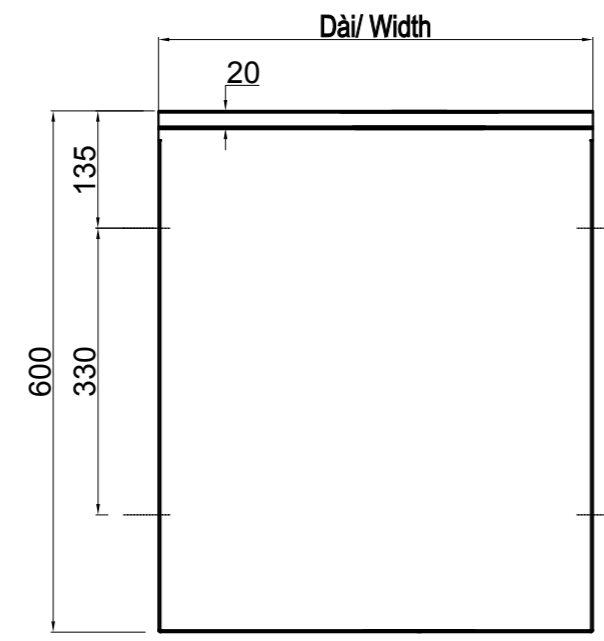

3D VIEW

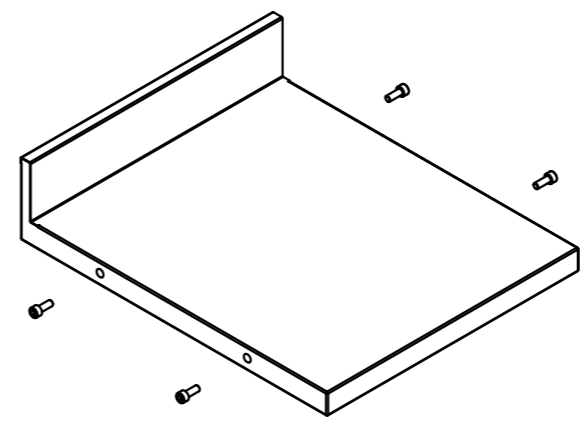

Khi mặt bàn ghép nối nằm giữa hai bàn

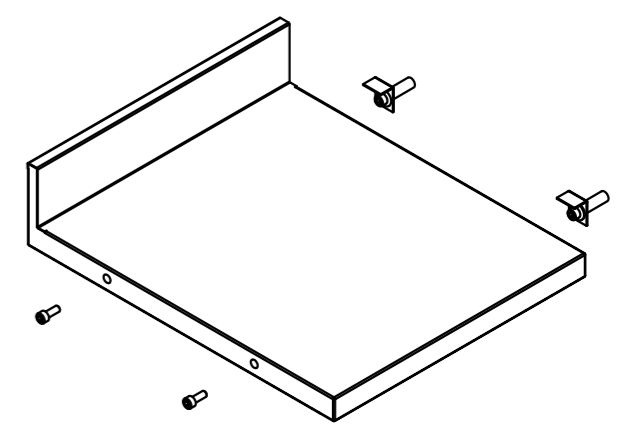

Khi mặt bàn ghép nối nằm giữa bàn và tường

THÔNG SỐ / SPECIFICATION

Vật liệu: Inox 201
 + Tấm mặt: inox 201#4 dày 1.0
 + Gân tăng cứng: Inox201 #4 dày 0.8
 + Ke góc bắt tường: Inox 201#4 dày 2.0
Kết cấu:
 + Bất ghép bằng bulong M6 dài 15 khi mặt bàn ghép nối nằm giữa hai bàn
 + Bất ke góc lên tường bằng bulong nở nhựa M6 khi bàn trung gian nằm giữa bàn và tường

THÔNG SỐ / SPECIFICATION



Khu / Area:

Date :...../7/17

Tên dự án/ Project name:

Scale : 1 : 20 (A4)

Tên thiết bị/ Equipment name:

BÀN GHEP NOI CO THANH SAU

Mã số No. item	S.Lg Q.TY	Kích thước/ Dimension (mm)		
		Dài/ Width	Sâu/ Depth	Cao/ Height
1		200	600	40/100
2		300	600	40/100
3		400	600	40/100
4		500	600	40/100

Submission Date: _____
 APPROVED
 APPROVED SUBJECT TO COMMENTS
 NOT APPROVED, RESUBMIT AS NOTED
 Approved by _____
 Date returned to contractor _____



HANDI HEAD OFFICE
 6th Floor, Intracom Building, 72 Lane, Tran Thai Tong Str., Cau Giay Dist., Hanoi, Vietnam
 Tel: +84 - 4 37 730 961
 Fax: +84 - 4 37 730 960
 Email: bepconghiep@hayencorp.vn
 Website: www.hayen.com.vn

HOCHIMINH OFFICE
 150/124 Cong Hoa Str., 12 Ward, Tan Binh Dist., HoChiMinh City, Viet Nam
 Tel: +84 - 8 3811 8925 /3811 4641 /3811 0612
 Fax: +84 - 8 38 116 376
 Email: bepconghiep@hayenind.com.vn
 Website: www.hayen.com.vn

Vẽ /Drawn: Hoàng Q Việt
 T.Kế/ Designed: Hoàng Q Việt
 K.Tra/ Checked: Lê văn Thiên